



PIXY WP SPECIFICATION

Release date: December 16, 2021 - V.1.0

SPECIFICATION

MECHANICAL & ELECTRICAL CHARACTERISTICS

Working Current	Static current: 400mA (@12V)
	Dynamic current: 800mA (@12V)
	Locked motor current: Max 4.0A (@12V)
Operating Temperature	5° F ~ 120° F (-15° C ~ 50° C)
Weight	1 lb (0.446 kg)
Gimbal Dimension	125(W) x 130(D) x 165(H)

PERIPHERAL

Camera Tray Dimensions	Maximum depth from the center of gravity on camera base plate: 38.4mm
	Maximum height measured from top of camera base plate: 64mm
	Maximum width: 85.7mm
Input Power	12V_5A, UBEC
Connections	USB 2.0, CAN, UART, S-bus, Spektrum, PPM, Bluetooth
PC Assistant Software Requirements	Windows XP or above; Mac OS X 10.9 or above
Mobile Assistant Software Requirements	iOS 7.1 or above; Android 4.3 or above

WORKING PERFORMANCE

Maximum Payload	450g
Angular Vibration Range	± 0.02°
Maximum Controlled Rotation Speed	Pan axis: 100°/s
	Tilt axis: 100°/s
	Roll axis: 100°/s
Mechanical Endpoint Range	Pan axis control: +330° to -330°
	Tilt axis control: +135° to -45°
	Roll axis control: +45° to -90°
Controlled Rotation Range	Pan axis control: +330° to -330°
	Tilt axis control: +135° to -45°
	Roll axis control: ± 45°

DIMENSION & CAMERA CAGE

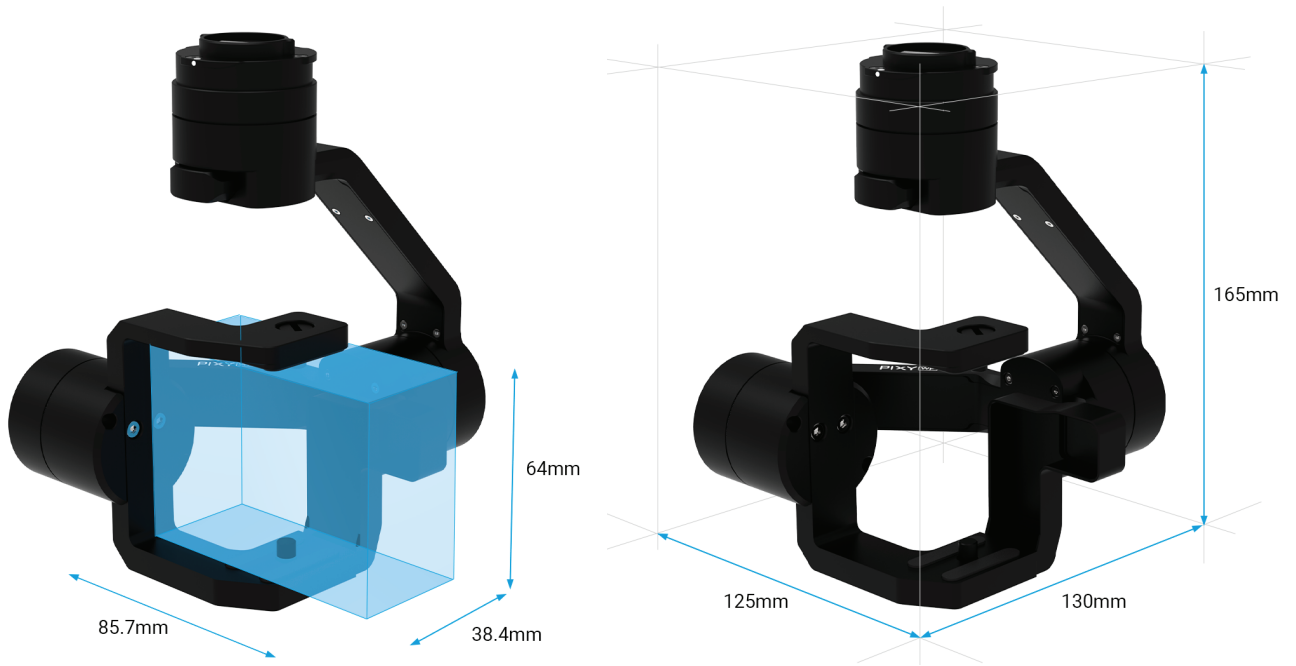

CAMERA COMPATIBILITY



Workswell Wiris Pro



Workswell Wiris Agro R

For more information, visit our website at: gremsy.com

For instant support, send us an email to contact@gremsy.com



[@GREMSYTECH](https://www.instagram.com/gremsytech)



[FACEBOOK.COM/GREMSY](https://www.facebook.com/gremsy)



[GREMSY.COM](https://www.gremsy.com)